

BOLT POCKET FORMER

The simple forming solution for tying together sections of box culvert or precast walls.

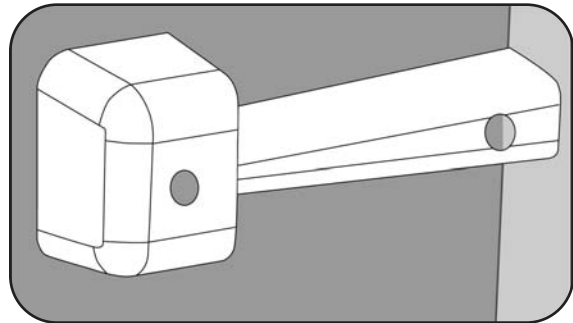

- 1.** Attach Bolt Pocket Former to form using either 1/4" bolts or plastic screws for non collapsing forms. The inserts are replaceable should the threads show signs of wear after numerous uses.

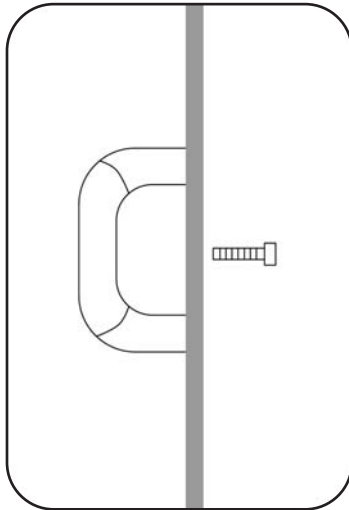
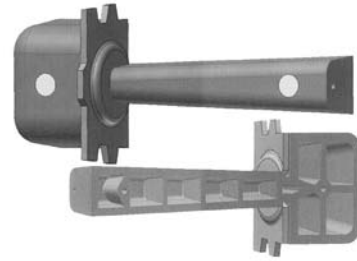
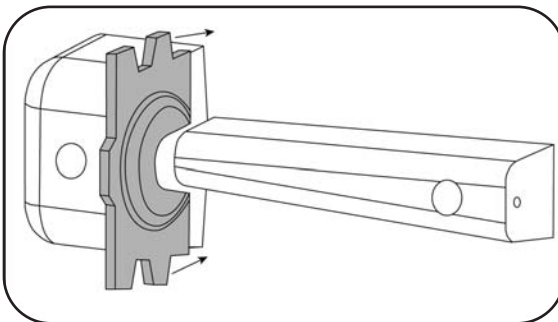

- 2.** Slide steel plate onto Bolt Pocket Former. Pour.

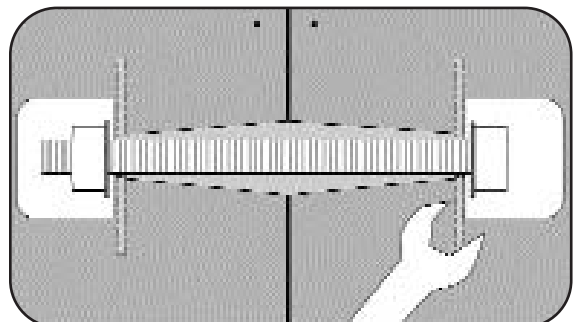

- 3.** After stripping form, slide Bolt Pocket Former out using pliers. Steel plate remains embedded in concrete. A groove through the joint and bolt pocket are formed. For field installation*, the steel plate accepts up to 1" rod.
*We provide a field installation kit consisting of rod, 2 nuts, and 2 washers for an additional charge.



FOR INFO. CALL 1-800-220-4857
or sales@pennsylvaniainsert.com