

Fax to:	Customer
Fax#	Project
From	Job#
Date	PA Insert Quote/Order#
	Ship Date
	Page ____ of ____

Approved/Notes

PA Insert Corp
 PO Box 199
 Spring City, PA 19475
 tel: 610-948-9688
 fax: 610-948-9750

email: sales@pennsylvaniainsert.com
 web: www.pennsylvaniainsert.com

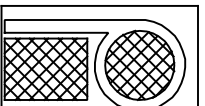

2" EXTENSION FOR 4" TERMINATOR (PVC)

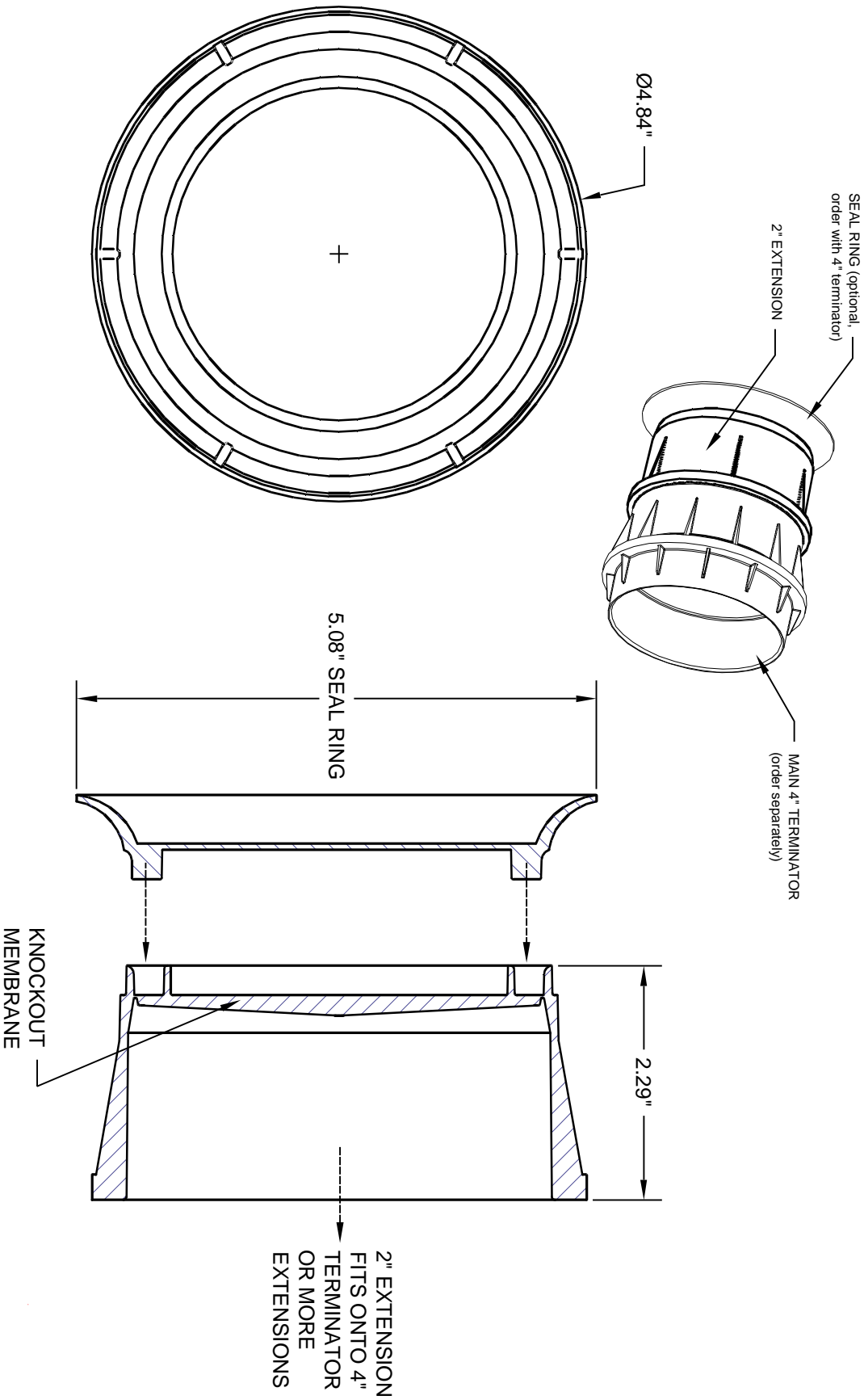

NO SCALE

06/08/04